



EN 55024: 1998 + A1: 2001 + A2: 2003  
TEST AND MEASUREMENT REPORT

For

**Super Micro Computer, Inc.**

980 Rock Avenue  
San Jose, CA 95131, USA

**Model: 5017C-MF, 5017C-MTF,  
1017C-TF AND 5017C-TF**

<b>Report Type:</b> Original Report	<b>Product Type:</b> Server
<b>Test Engineer:</b> Jerry Wang	
<b>Report Number:</b> R1103023-2A	
<b>Report Date:</b> 2011-04-13	
<b>Reviewed By:</b> Vang Her EMC Lead	
<b>Prepared By:</b> (84)	Bay Area Compliance Laboratories Corp. 1274 Anvilwood Ave Sunnyvale, CA 94089, USA Tel: (408) 732-9162 Fax: (408) 732 9164

**Note:** This test report is prepared for the customer shown above and for the device described herein. It may not be duplicated or used in part without prior written consent from Bay Area Compliance Laboratories Corp. This report **must not** be used by the customer to claim product certification, approval, or endorsement by NVLAP\*, NIST, or any agency of the Federal Government.

\* This report may contain data that are not covered by the NVLAP accreditation and are marked with an asterisk "\*" and.

Based on the declaration of similarity (Appendix I), the following models are similar.

<b>Models Covered by the Declaration of Similarity</b>
5017C-TF
5017C-LF
5017C-MTRF
5017C-MF
5017C-MTF

## TABLE OF CONTENTS

<b>1</b>	<b>GENERAL DESCRIPTION .....</b>	<b>7</b>
1.1	PRODUCT DESCRIPTION FOR EQUIPMENT UNDER TEST (EUT) .....	7
1.2	MECHANICAL DESCRIPTION .....	7
1.3	EUT PHOTO .....	8
1.4	OBJECTIVE .....	8
1.5	RELATED SUBMITTAL(S)/GRANT(S).....	9
1.6	TEST METHODOLOGY .....	9
1.7	MEASUREMENT UNCERTAINTY.....	9
1.8	TEST FACILITY.....	9
<b>2</b>	<b>PERFORMANCE CRITERIA .....</b>	<b>10</b>
2.1	AS PER EN 55024 §7: PERFORMANCE CRITERIA.....	10
2.2	GENERAL PERFORMANCE CRITERIA .....	10
<b>3</b>	<b>EUT TEST CONFIGURATION.....</b>	<b>11</b>
3.1	JUSTIFICATION .....	11
3.2	EUT EXERCISE SOFTWARE.....	11
3.3	EQUIPMENT MODIFICATIONS .....	11
3.4	SPECIAL EQUIPMENT .....	11
3.5	LOCAL SUPPORT EQUIPMENT EUT INTERNAL CONFIGURATION DETAILS: 5017C-TF ( X9SCM-F) ( 811-3) .	11
3.6	EUT INTERNAL CONFIGURATION DETAILS: 1017C-TF ( X9SCL-F) ( 111-3) .....	12
3.7	EQUIPMENT AND INTERFACE PORT/CABLE ARRANGEMENT .....	12
<b>4</b>	<b>SUMMARY OF TEST RESULTS.....</b>	<b>13</b>
<b>5</b>	<b>EN 55024 §4.2.1 – ELECTROSTATIC DISCHARGE EN 61000-4-2.....</b>	<b>14</b>
5.1	APPLICABLE STANDARD .....	14
5.2	ELECTROSTATIC DISCHARGE TEST SYSTEM .....	14
5.3	ELECTROSTATIC DISCHARGE MEASUREMENT UNCERTAINTY .....	14
5.4	APPLICATION OF ELECTROSTATIC DISCHARGES .....	15
5.5	TEST SETUP BLOCK DIAGRAM.....	15
5.6	ENVIRONMENTAL CONDITIONS.....	16
5.7	TEST EQUIPMENT LIST AND DETAILS .....	16
5.8	ELECTROSTATIC DISCHARGE TEST DATA (EN 61000-4-2).....	17
<b>6</b>	<b>EN 55024 §4.2.3.1 – CONTINUOUS RADIATED DISTURBANCES EN 61000-4-3.....</b>	<b>18</b>
6.1	APPLICABLE STANDARD .....	18
6.2	CONTINUOUS RADIATED DISTURBANCES TEST SYSTEM.....	18
6.3	CONTINUOUS RADIATED DISTURBANCES MEASUREMENT UNCERTAINTY.....	18
6.4	APPLICATION OF CONTINUOUS RADIATED DISTURBANCES .....	18
6.5	TEST SETUP BLOCK DIAGRAM.....	19
6.6	ENVIRONMENTAL CONDITIONS.....	19
6.7	TEST EQUIPMENT LIST.....	20
6.8	CONTINUOUS RADIATED DISTURBANCES TEST DATA (EN 61000-4-3) .....	20
<b>7</b>	<b>EN 55024 §4.2.2 – ELECTRICAL FAST TRANSIENTS EN 61000-4-4 .....</b>	<b>21</b>
7.1	APPLICABLE STANDARD .....	21
7.2	ELECTRICAL FAST TRANSIENTS TEST SYSTEM .....	21
7.3	ELECTRICAL FAST TRANSIENTS MEASUREMENT UNCERTAINTY .....	21
7.4	APPLICATION OF ELECTRICAL FAST TRANSIENTS .....	22
7.5	TEST SETUP BLOCK DIAGRAM.....	22
7.6	ENVIRONMENTAL CONDITIONS.....	23
7.7	TEST EQUIPMENT LIST.....	23
7.8	ELECTRICAL FAST TRANSIENT TEST DATA (EN 61000-4-4) .....	24

**8 EN 55024 §4.2.5 – SURGES EN 61000-4-5 .....25**

8.1 APPLICABLE STANDARD ..... 25

8.2 SURGES TEST SYSTEM ..... 25

8.3 SURGES MEASUREMENT UNCERTAINTY ..... 25

8.4 APPLICATION OF SURGES ..... 25

8.5 TEST SETUP BLOCK DIAGRAM..... 26

8.6 ENVIRONMENTAL CONDITIONS..... 26

8.7 TEST EQUIPMENT LIST..... 27

8.8 SURGES TEST DATA (EN 61000-4-5)..... 27

**9 EN 55024 §4.2.3.2 – CONTINUOUS CONDUCTED DISTURBANCE EN 61000-4-6..... 28**

9.1 APPLICABLE STANDARD ..... 28

9.2 CONTINUOUS CONDUCTED DISTURBANCE TEST ..... 28

9.3 CONTINUOUS CONDUCTED DISTURBANCE MEASUREMENT UNCERTAINTY ..... 28

9.4 APPLICATION OF CONTINUOUS CONDUCTED DISTURBANCE..... 28

9.5 TEST SETUP BLOCK DIAGRAM..... 29

9.6 ENVIRONMENTAL CONDITIONS..... 29

9.7 TEST EQUIPMENT LIST..... 30

9.8 CONTINUOUS CONDUCTED DISTURBANCE TEST DATA (EN 61000-4-6)..... 30

**10 EN 55024 §4.2.6 – VOLTAGE DIPS AND INTERRUPTIONS EN 61000-4-11..... 31**

10.1 APPLICABLE STANDARD ..... 31

10.2 VOLTAGE DIPS AND INTERRUPTIONS TEST SYSTEM ..... 31

10.3 VOLTAGE DIPS AND INTERRUPTIONS MEASUREMENT UNCERTAINTY ..... 31

10.4 APPLICATION OF VOLTAGE DIPS AND INTERRUPTIONS ..... 31

10.5 TEST SETUP BLOCK DIAGRAM..... 32

10.6 ENVIRONMENTAL CONDITIONS..... 32

10.7 TEST EQUIPMENT LIST..... 33

10.8 VOLTAGE DIPS AND INTERRUPTIONS TEST DATA (EN 61000-4-11)..... 33

**11 EXHIBIT A - CE PRODUCT LABELING REQUIREMENTS..... 34**

11.1 LABEL INFORMATION ..... 34

11.2 LABEL LOCATION ON EUT ..... **ERROR! BOOKMARK NOT DEFINED.**

**12 EXHIBIT B – TEST SETUP PHOTOGRAPHS ..... 37**

12.1 ELECTROSTATIC DISCHARGE (EN 61000-4-2)-5017C-TF ..... 37

12.2 ESD CONTACT POINTS VIEW 1 – (DIRECT CONTACT – **BLUE LINE**, AIR CONTACT – **RED LINE**)-5017C-TF ... 37

12.3 ESD CONTACT POINTS VIEW 2 – (DIRECT CONTACT – **BLUE LINE**, AIR CONTACT – **RED LINE**)-5017C-TF... 38

12.4 ELECTROSTATIC DISCHARGE (EN 61000-4-2)-1017C-TF ..... 38

12.5 ESD CONTACT POINTS VIEW 1 – (DIRECT CONTACT – **BLUE LINE**, AIR CONTACT – **RED LINE**)-1017C-TF ... 39

12.6 ESD CONTACT POINTS VIEW 2 – (DIRECT CONTACT – **BLUE LINE**, AIR CONTACT – **RED LINE**)-1017C-TF... 39

12.7 CONTINUOUS RADIATED IMMUNITY (EN 61000-4-3)-FRONT VIEW-5017C-TF ..... 40

12.8 CONTINUOUS RADIATED IMMUNITY (EN 61000-4-3)-FRONT VIEW-1017C-TF ..... 40

12.9 ELECTRICAL FAST TRANSIENTS (EN 61000-4-4) – AC LINE-5017C-TF ..... 41

12.10 ELECTRICAL FAST TRANSIENTS (EN 61000-4-4) – AC LINE-1017C-TF ..... 41

12.11 ELECTRICAL FAST TRANSIENTS (EN 61000-4-4) – SIGNAL LINE-5017C-TF ..... 42

12.12 ELECTRICAL FAST TRANSIENTS (EN 61000-4-4) – SIGNAL LINE-1017C-TF ..... 42

12.13 SURGES (EN 61000-4-5)-AC LINE-5017C-TF..... 43

12.14 SURGES (EN 61000-4-5)-AC LINE-1017C-TF..... 43

12.15 CONTINUOUS CONDUCTED IMMUNITY (EN 61000-4-6) – POWER LINE-5017C-TF ..... 44

12.16 CONTINUOUS CONDUCTED IMMUNITY (EN 61000-4-6) – POWER LINE-1017C-TF ..... 44

12.17 CONTINUOUS CONDUCTED IMMUNITY (EN 61000-4-6) – SIGNAL LINE-5017C-TF..... 45

12.18 CONTINUOUS CONDUCTED IMMUNITY (EN 61000-4-6) – SIGNAL LINE-1017C-TF..... 45

12.19 VOLTAGE DIPS AND INTERRUPTIONS (EN 61000-4-11)-5017C-TF ..... 46

12.20 VOLTAGE DIPS AND INTERRUPTIONS (EN 61000-4-11)-1017C-TF ..... 46

**13 EXHIBIT C – EUT PHOTOGRAPHS..... 47**

13.1 EUT FRONT VIEW-5017C-TF..... 47

13.2 EUT REAR VIEW-5017C-TF ..... 47

---

<b>13.3</b>	EUT CHASSIS OPEN VIEW-5017C-TF .....	48
<b>13.4</b>	EUT FRONT VIEW -1017C-TF.....	48
<b>13.5</b>	EUT REAR VIEW -1017C-TF.....	49
<b>13.6</b>	EUT COVER OFF VIEW -1017C-TF.....	49
<b>13.7</b>	EUT POWER TOP VIEW-5017C-TF.....	50
<b>13.8</b>	EUT POWER TOP VIEW-1017C-TF.....	50
<b>14</b>	<b>APPENDIX I - DECLARATION OF SIMILARITY .....</b>	<b>51</b>

**DOCUMENT REVISION HISTORY**

Revision Number	Report Number	Description of Revision	Date of Revision
0	R1103023-2	Original Report	2011-04-05

# 1 General Description

---

## 1.1 Product Description for Equipment Under Test (EUT)

This test and measurement report has been prepared on behalf of the company *Super Micro Computer, Inc.* and their product, model: 1017C-TF and 5017C-TF, which will be henceforth in this report referred to as the EUT (Equipment Under Test). The EUT is a storage processing Server. From series models 5017C-TF, 5017C-MF, and 5017C-MTF model 5017C-TF was found to be the worst case, full immunity testing was completed on model 5017C-TF.

## 1.2 Mechanical Description

The EUT-5017C-TF measures approximately **55cm (L) x 43.5cm (W) x 4.2cm (H)**

*The data gathered are from a production sample provided by the manufacturer. Serial number: C811010D2K50195*

The EUT-1017C-TF measures approximately **56cm (L) x 43 cm (W) x 4.2cm (H)**

*The data gathered are from a production sample provided by the manufacturer. Serial number: C11100025A00097*

### 1.3 EUT Photo

*1017C-TF*



*5017C-TF*



*Please see additional photos in exhibit C*

### 1.4 Objective

This report is prepared on behalf of *Super Micro Computer, Inc.* in accordance with EN 55024:1998 +A1:2001 +A2:2003 for Information Technology Equipment – Immunity Characteristics – Limits and Methods of Measurements.

The objective is to determine compliance in accordance with EN 55024:1998 +A1:2001 +A2:2003 immunity requirements for Information Technology Equipment.



## 1.5 Related Submittal(s)/Grant(s)

No related submittals.

## 1.6 Test Methodology

All measurements contained in this report were conducted in accordance with EN 55024:1998 +A1:2001 +A2:2003, European Standard for Information Technology Equipment – Immunity Characteristics – Limits and Methods of Measurement.

All immunity test measurements were performed at Bay Area Compliance Laboratories Corp.

## 1.7 Measurement Uncertainty

All measurements involve certain levels of uncertainties, especially in the field of EMC. The factors contributing to uncertainties are spectrum analyzer, cable loss, antenna factor calibration, antenna directivity, antenna factor variation with height, antenna phase center variation, antenna factor frequency interpolation, measurement distance variation, site imperfections, mismatch (average), and system repeatability.

Based on NIS 81, The Treatment of Uncertainty in EMC Measurements, the values ranging from  $\pm 2.0$  dB for Conducted Emissions tests and  $\pm 4.0$  dB for Radiated Emissions tests are the most accurate estimates pertaining to uncertainty of EMC measurements at BACL Corp.

Detailed instrumentation measurement uncertainties can be found in BACL Corp. report QAP-018.

## 1.8 Test Facility

The test site used by BACL Corp. to collect immunity measurement data is located at its facility in Sunnyvale, California, USA.

The test sites at BACL have been fully described in reports submitted to the Federal Communication Commission (FCC) and Voluntary Control Council for Interference (VCCI). The details of these reports has been found to be in compliance with the requirements of Section 2.948 of the FCC Rules on February 11 and December 10, 1997 and Article 8 of the VCCI regulations on December 25, 1997. The facility also complies with the radiated and AC line conducted test site criteria set forth in ANSI C63.4-2003.

The Federal Communications Commission, Industry Canada, and Voluntary Control Council for Interference has the reports on file and is listed under FCC registration number: 90464, IC registration number: 3062A, and VCCI Registration Number: C-2698 and R-2463. The test site has been approved by the FCC, IC, and VCCI for public use and is listed in the FCC Public Access Link (PAL) database.

Additionally, BACL is a National Institute of Standards and Technology (NIST) accredited laboratory, under the National Voluntary Laboratory Accredited Program (Lab Code 200167-0). The current scope of accreditations can be found at <http://ts.nist.gov/Standards/scopes/2001670.htm>

## **2 Performance Criteria**

---

### **2.1 As per EN 55024 §7: Performance Criteria**

The manufacturer has the obligation to express the performance criteria in terms which relate to the performance of his specific product when used as intended.

The following performance criteria are applicable, and shall only be evaluated when the functions referred to are implemented.

### **2.2 General Performance Criteria**

Examples of functions defined by the manufacturer to be evaluated during testing include, but are not limited to, the following:

- Essential operational modes and states;
- Tests of all peripheral access (hard disks, floppy disks, printers, keyboard, mouse, etc.);
- Quality of software execution;
- Quality of data display and transmission;
- Quality of speech transmission.

#### **Performance Criterion A**

The equipment shall continue to operate as intended without operator intervention. No degradation of performance or loss of function is allowed below a performance level specified by the manufacturer when the equipment is used as intended. The performance level may be replaced by a permissible loss of performance. If the minimum performance level or the permissible performance loss is not specified by the manufacturer, then either of these may be derived from the product description and documentation, and by what the user may reasonably expect from the equipment if used as intended.

#### **Performance Criterion B**

After the test, the equipment shall continue to operate as intended without operator intervention. No degradation of performance or loss of function is allowed, after the application of the phenomena below a performance level specified by the manufacturer, when the equipment is used as intended. The performance level may be replaced by a permissible loss of performance.

During the test, degradation of performance is allowed. However, no change of operating state or stored data is allowed to persist after the test.

If the minimum performance level (or the permissible performance loss) is not specified by the manufacturer, then either of these may be derived from the product description and documentation, and by what the user may reasonably expect from the equipment if used as intended.

#### **Performance Criterion C**

Loss of function is allowed, provided the function is self-recoverable, or can be restored by the operation of the controls by the user in accordance with the manufacturer's instructions. Functions, and/or information stored in non-volatile memory, or protected by a battery backup, shall not be lost.

### 3 EUT TEST CONFIGURATION

#### 3.1 Justification

The EUT was configured for testing according to EN 55024:1998 +A1:2001 +A2:2003 Standard.

#### 3.2 EUT Exercise Software

The Software to exercise the unit was provided by the client. The name of the software is called Burn-In Test, it utilizes the hardware to operate at maximum capacity.

#### 3.3 Equipment Modifications

N/A

#### 3.4 Special Equipment

N/A

#### 3.5 Local Support Equipment EUT Internal Configuration Details: 5017C-TF ( X9SCM-F) ( 811-3)

Manufacturers	Descriptions	Model Number	Serial Number
Ablecom	Chassis	CSE-811	C81101002k50195
Super Micro	Power Supply (x2)	PWS-351-1H	P35110951IN0046
Super Micro	Main board	X9SCM-F	WM11S31598
Super Micro	Backplane	SAS810TQ	EB03537094
Intel	CPU	XEON E31230	N/A
Hynix	RAM (x 2)	HMT125U7BF	N/A
Super Micro	Front panel	PPUSB	N/A
Delta	Fan (x2)	BFB1012VH	N/A
WD	HDD	WD1601ABY	WCAS2C668770

### 3.6 EUT Internal Configuration Details: 1017C-TF ( X9SCL-F) ( 111-3)

Manufacturers	Descriptions	Model Number	Serial Number
Ablecom	Chassis	CSE-111	C11100025A00097
Super Micro	Power Supply (x2)	PWS-333-1H	672042055371
Super Micro	Main board	X9SCL-F	ZM11U35977
Super Micro	Backplane	SAS809T	PB96S00686
Intel	CPU	XEON E31270	N/A
Hynix	RAM (x 2 )	HMT125U7B	N/A
Delta	Fan (x2)	FFB0412SHN	N/A
WD	HDD	WD1601ABY	WCAS2C6676781
Super Micro	Riser card	RR1U-E8	N/A

### 3.7 Equipment and Interface Port/Cable Arrangement

Cable Type	Length (M)	From	To
VGA	1	Monitor	EUT
USB	1.5	Mouse	EUT
USB	1.5	Keyboard	EUT
USB	1.5	Keyboard	EUT
USB	1.5	Keyboard	EUT
Serial cable	1.5	Modem	EUT
RJ45	1.5	EUT	EUT

## 4 Summary of Test Results

Standards	Description Of Test	Result
EN 55024 §4.2.1	Electrostatic Discharges EN 61000-4-2	Compliant
EN 55024 §4.2.3.1	Continuous Radiated Disturbances EN 61000-4-3	Compliant
EN 55024 §4.2.2	Electrical Fast Transients EN 61000-4-4	Compliant
EN 55024 §4.2.5	Surges EN 61000-4-5	Compliant
EN 55024 §4.2.3.2	Continuous Conducted Disturbances EN 61000-4-6	Compliant
EN 55024 §4.2.4	Power-frequency Magnetic Fields EN 61000-4-8	N/A <sup>1</sup>
EN 55024 §4.2.6	Voltage Dips and Interruptions EN 61000-4-11	Compliant

1) Note: The EUT is not sensitive to magnetic fields.

## 5 EN 55024 §4.2.1 – Electrostatic Discharge EN 61000-4-2

### 5.1 Applicable Standard

#### As per EN 61000-4-2 §5: Test Levels

The preferential range of test levels for the ESD test is given in table 1.

Testing shall also be satisfied at the lower levels given in table 1.

Details concerning the various parameters which may influence the voltage level to which the human body may be charged are given in clause A.2 of annex A. Clause A.4 also contains examples of the application of the test levels related to environmental (installation) classes.

Contact discharge is the preferred test method. Air discharges shall be used where contact discharge cannot be applied. Voltages for each test method are given in tables 1 a and 1 b.

The voltages shown are different for each method due to the differing methods of test. It is not intended to imply that the test severity is equivalent between test methods.

Further information is given in clauses A.3, A.4 and A.5 of annex A.

**Table 1- Test levels**

1a-Contact discharge		1b- Air discharge	
Level	Test voltage (kV)	Level	Test voltage (kV)
1	2	1	2
2	4	2	4
3	6	3	8
4	8	4	15
x <sup>1)</sup>	Special	x <sup>1)</sup>	Special

<sup>1)</sup> "x" is an open level. The level has to be specified in the dedicated equipment specification. If higher voltages than those shown are specified, special test equipment may be needed.

### 5.2 Electrostatic Discharge Test System

The Schaffner NSG 435 ESD used for testing, is capable of applying Electrostatic Discharges in both contact discharge modes from 2 kV to 4 kV and air discharge modes from 2 kV to 8 kV in both positive and negative polarities, in accordance with EN 61000-4-2 EMC testing standard and methods.

### 5.3 Electrostatic Discharge Measurement Uncertainty

The measurement uncertainty with a 95% confidence factor has determined that the applied voltage has a maximum variance of  $\pm 5\%$  of the stated applied value.

### 5.4 Application of Electrostatic Discharges

The test was conducted in the following order: Air Discharge, Direct Contact Discharge, Indirect Contact Horizontal Coupling Plane Discharge, and Indirect Contact Vertical Coupling Plane Discharge. The Electrostatic Discharge test levels were set and discharged appropriately. The Electrostatic Discharges are applied to the conductive surface of the EUT, and along all seams and control surfaces on the EUT. When a discharge occurs and an error is caused, the type of error, discharge level and location is recorded.

### 5.5 Test Setup Block Diagram

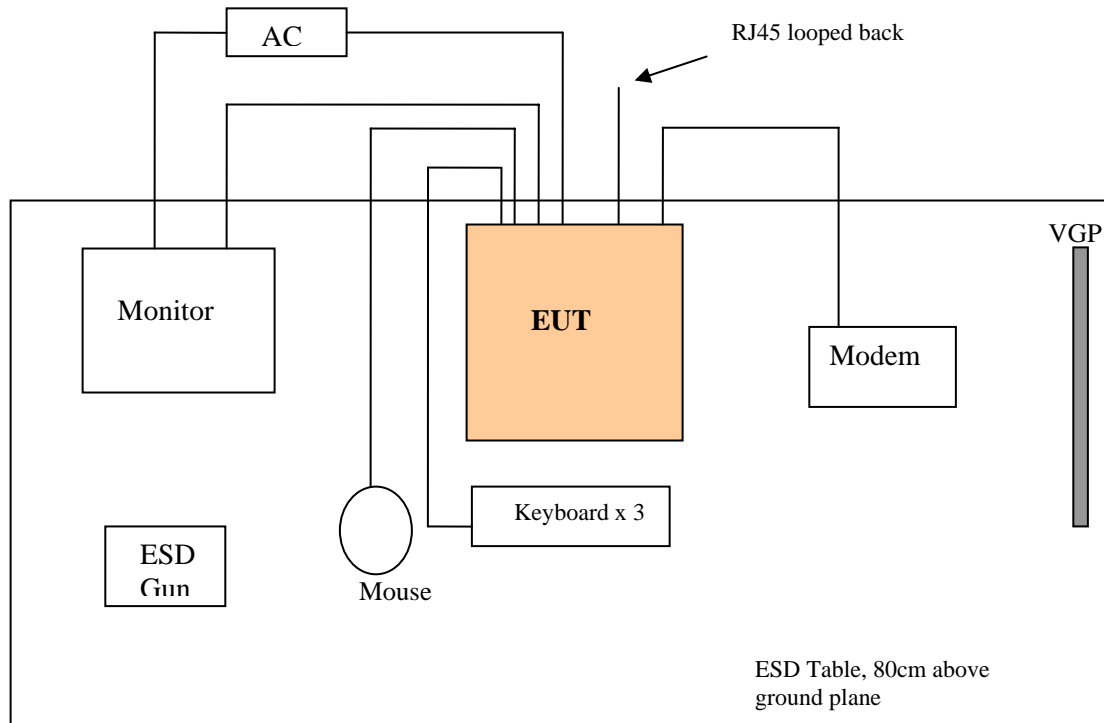

## 5.6 Environmental Conditions

### 5017C-TF, 5017C-MF, 5017C-MTF

<b>Temperature:</b>	21.34 °C
<b>Relative Humidity:</b>	36 %
<b>ATM Pressure:</b>	102.14 kPa

Testing was performed by Arthur Tie on 2011-03-12 in Immunity room 1B.

### 1017C-TF

<b>Temperature:</b>	21.34 °C
<b>Relative Humidity:</b>	36 %
<b>ATM Pressure:</b>	102.14 kPa

Testing was performed by Arthur Tie on 2011-03-14 in Immunity room 1B.

## 5.7 Test Equipment List and Details

Manufacturer	Description	Model	Serial Number	Calibration Date
Schaffner	ESD Gun	NSG 435	5255	2010-11-24

**Statement of Traceability:** BAACL Corp. attests that all calibrations have been performed according to NVLAP requirements, traceable to the NIST.



### 5.8 Electrostatic Discharge Test Data (EN 61000-4-2)

**Table 1: Electrostatic Discharge (Air Discharge)**

EN 61000-4-2 Test Point	Test Level (kV)											
	-2	+2	-4	+4	-6	+6	-8	+8	-15	+15	-20	+20
EUT Front Side	A	A	A	A	-	-	A	A	-	-	-	-
EUT Back Side	A	A	A	A	-	-	A	A	-	-	-	-

**Table 2: Electrostatic Discharge (Direct Contact)**

EN 61000-4-2 Test Point	Test Level (kV)											
	-2	+2	-4	+4	-6	+6	-8	+8	-15	+15	-20	+20
EUT Front Side	A	A	A	A	-	-	-	-	-	-	-	-
EUT Back Side	A	A	A	A	-	-	-	-	-	-	-	-
EUT Ports	A	A	A	A	-	-	-	-	-	-	-	-

**Table 3: Electrostatic Discharge (Indirect Contact HCP)**

EN 61000-4-2 Test Point	Test Level (kV)											
	-2	+2	-4	+4	-6	+6	-8	+8	-15	+15	-20	+20
EUT Front Side	A	A	A	A	-	-	-	-	-	-	-	-
EUT Back Side	A	A	A	A	-	-	-	-	-	-	-	-
EUT Left Side	A	A	A	A	-	-	-	-	-	-	-	-
EUT Right Side	A	A	A	A	-	-	-	-	-	-	-	-

**Table 4: Electrostatic Discharge (Indirect Contact VCP)**

EN 61000-4-2 Test Point	Test Level (kV)											
	-2	+2	-4	+4	-6	+6	-8	+8	-15	+15	-20	+20
EUT Front Side	A	A	A	A	-	-	-	-	-	-	-	-
EUT Back Side	A	A	A	A	-	-	-	-	-	-	-	-
EUT Left Side	A	A	A	A	-	-	-	-	-	-	-	-
EUT Right Side	A	A	A	A	-	-	-	-	-	-	-	-

Note:           A ----- Performance Criteria A  
                   B ----- Performance Criteria B  
                   C ----- Performance Criteria C  
                   - ----- Not Applicable

The EUT was subjected to Electrostatic Discharge Test required by EN 55024:1998 + A1:2001 + A2:2003 and all lower levels specified by EN 61000-4-2.

Models 5017C-MF, 5017C-MTF, 5017C-TF and 1017C-TF have the same test results

## 6 EN 55024 §4.2.3.1 – Continuous Radiated Disturbances EN 61000-4-3

### 6.1 Applicable Standard

The preferential range of test levels is given in table 1.

Frequency range: 80 MHz to 1 000 MHz.

Table 1- Test levels

Level	Test field strength (V/m)
1	1
2	3
3	10
x	special
NOTE x is an open test level. This level may be given in the product specification.	

Table 1 gives details of the field strength of the unmodulated signal. For testing of equipment, this signal is 80 % amplitude modulated with a 1 kHz sinewave to simulate actual threats (see figure 1). Details of how the test is performed are given in clause 8.

NOTE 1 Product committees may decide to choose a lower or higher transition frequency than 80 MHz between IEC 61000-4-3 and IEC 61000-4-6 (see annex H).

NOTE 2 Product committees may select alternative modulation schemes.

NOTE 3 IEC 61000-4-6 also defines test methods for establishing the immunity of electrical and electronic equipment against radiated electromagnetic energy. It covers frequencies below 80 MHz.

### 6.2 Continuous Radiated Disturbances Test System

HP 8648C signal generator and a M423 power amplifier are used to provide a signal at the appropriate power and frequency to a biconilog antenna to obtain the required electromagnetic field at the position of the EUT in accordance with the EN 61000-4-3 EMC standard and methods.

### 6.3 Continuous Radiated Disturbances Measurement Uncertainty

The measurement uncertainty with a 95 % confidence factor has determined that the applied field has an expanded uncertainty value of 1.97. This yields an uncertainty of 0.15 V (rms) in the applied filed levels.

### 6.4 Application of Continuous Radiated Disturbances

The electromagnetic field is established at the front edge of the EUT. The frequency range is swept from 80 to 1000 MHz using a power level necessary to obtain a 3 volt/meter, 1 kHz AM sine wave modulated at 80% depth, field directed at the EUT. The test is performed with the most susceptible side of the EUT facing the field-generating antenna. If an error is detected, the field is reduced until the error is not repeatable; the field is then manually increased until the error begins to occur. At this threshold level, the frequency and error created are noted before continuing the scan.

### 6.5 Test Setup Block Diagram

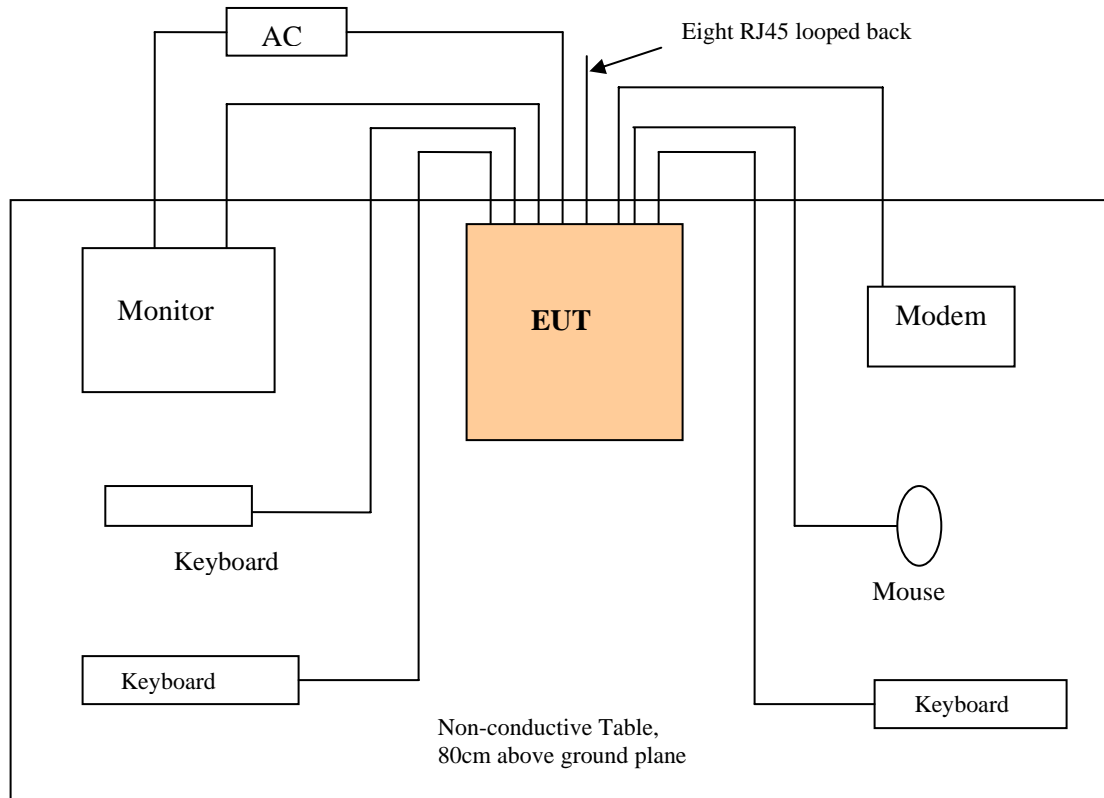

### 6.6 Environmental Conditions

#### 5017C-TF

<b>Temperature:</b>	22.54 °C
<b>Relative Humidity:</b>	55%
<b>ATM Pressure:</b>	105 kPa

Testing was performed by Angel Escamilla on 2011-03-04 in 5 meter chamber 2.

#### 1017C-TF

<b>Temperature:</b>	21.76 °C
<b>Relative Humidity:</b>	45%
<b>ATM Pressure:</b>	103.12 kPa

Testing was performed by Angel Escamilla on 2011-03-07 in 5 meter chamber 2.

## 6.7 Test Equipment List

Manufacturer	Description	Model	Serial Number	Calibration Date
IFI	Wideband Amplifier	M423	1192-4213	N/R
HP	Signal Generator	8648C	3426A00417	2010-08-30
Sunol Sciences	System Controller	SC99V	110031	N/R
Sunol Sciences	Turn-Table	SM46C	N/A	N/R
Sunol Sciences	Tower, Antenna	TWR99-4	11003-3	N/R
ETS	Log-Periodic Antenna	3140	1019	N/R
Agilent	Power Sensor	E9301A	US39211706	2010-03-26
ETS-Lindgren	Electric Field Sensor	HI-4550	51958	2010-06-11

**Statement of Traceability:** BACL Corp. attests that all calibrations or verifications have been performed according to NVLAP requirements, traceable to the NIST.

## 6.8 Continuous Radiated Disturbances Test Data (EN 61000-4-3)

Frequency Range (MHz)	Front Side (3 V/m)		Rear Side (3 V/m)		Left Side (3 V/m)		Right Side (3 V/m)	
	VERT	HORI	VERT	HORI	VERT	HORI	VERT	HORI
80 – 1000	A	A	A	A	A	A	A	A

Note: A ----- Performance Criteria A  
 B ----- Performance Criteria B  
 C ----- Performance Criteria C  
 - ----- Not Applicable

The EUT was subjected to a 3-volt/meter, 80% Amplitude modulated, 1 kHz sine wave field as required by EN 55024: 1998 + A1: 2001 + A2: 2003 and the level specified by EN 61000-4-3.

Both EUT have the same results

## 7 EN 55024 §4.2.2 – Electrical Fast Transients EN 61000-4-4

### 7.1 Applicable Standard

#### As per EN 61000-4-4 §5: Test Levels

The preferential range of test levels for the electrical fast transient test, applicable to power, ground, signal and control ports of the equipment are given in table 1.

**Table 1- Test levels**

Open circuit output test voltage and repetition rate of the impulses				
Level	On power port, PE		On I/O (input/output) signals, data and control ports	
	Voltage peak (kV)	Repetition rate (kHz)	Voltage peak (kV)	Repetition rate (kHz)
1	0.5	5 or 100	0.25	5 or 100
2	1	5 or 100	0.5	5 or 100
3	2	5 or 100	1	5 or 100
4	4	5 or 100	2	5 or 100
X <sup>1)</sup>	Special	Special	Special	Special

NOTE 1 Use of 5 kHz repetition rates is traditional; however, 100 kHz is closer to reality. Product committees should determine which frequencies are relevant for specific products or product types.

NOTE 2 With some products, there may be no clear distinction between power ports and I/O ports, in which case it is up to product committees to make this determination for test purposes.

“X” is an open level. The level has to be specified in the dedicated equipment specification.

These open-circuit output voltages will be displayed on the EFT/B generator. For selection of levels, see Annex B.

### 7.2 Electrical Fast Transients Test System

An EM Test Immunity Simulator is used for all testing. It is capable of applying fast transients to the AC line at any phase angle with respect to the AC line voltage wave form and to attached cables via a capacitive coupling clamp in accordance with the EN 61000-4-4 EMC standard and methods.

### 7.3 Electrical Fast Transients Measurement Uncertainty

The measurement uncertainty with a 95% confidence factor has determined that the applied field has an expanded uncertainty value of 1.97.

### 7.4 Application of Electrical Fast Transients

The EUT was arranged for Power Line Coupling with a coupling/decoupling network and for I/O Line Coupling through a capacitive clamp, where applicable. (Note: The I/O coupling test using a capacitive clamp is performed on the I/O interface cables that are longer in length than 3 meters.) A metal ground plane 2.4 meter by 2.0 meter was placed between the floor and the table and is connected to the earth by a 2.0 meter ground rod. The ground rod is connected to the test facility’s electrical earth. The distance between the CDN and any other conductive surface was 50cm.

### 7.5 Test Setup Block Diagram

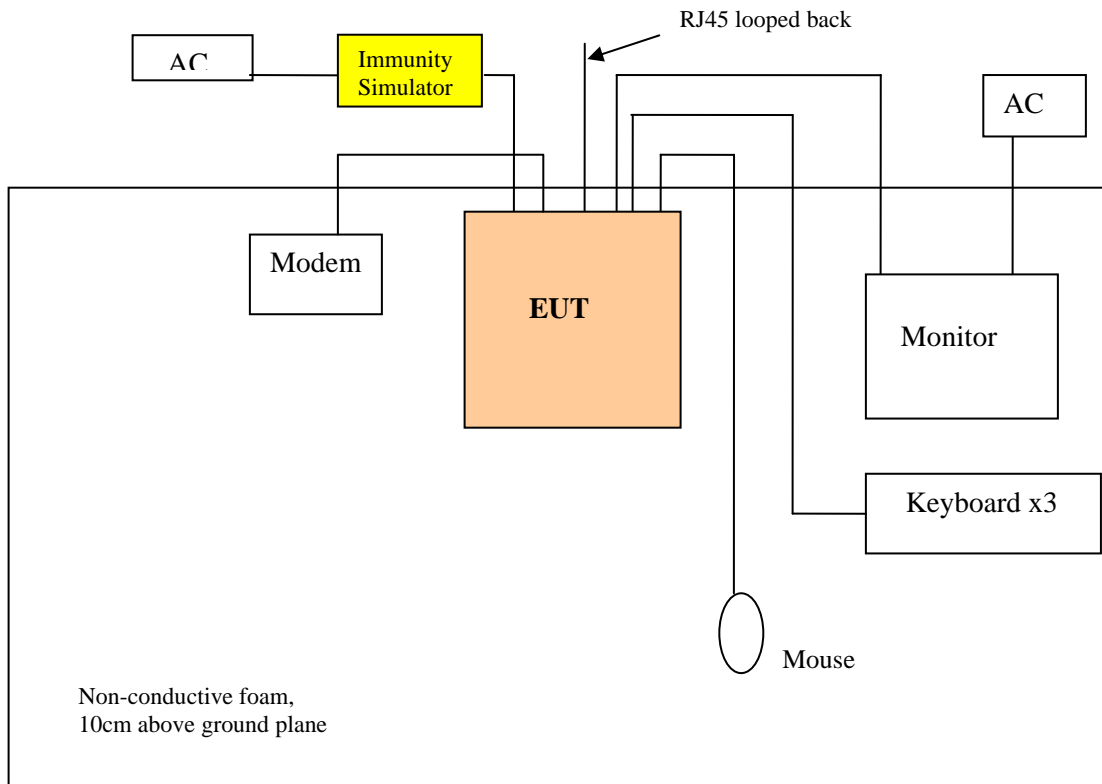

## 7.6 Environmental Conditions

### 5017C-TF

<b>Temperature:</b>	22.54 °C
<b>Relative Humidity:</b>	55%
<b>ATM Pressure:</b>	105 kPa

Testing was performed by Angel Escamilla on 2011-03-04 in 5 meter chamber 2.

### 1017C-TF

<b>Temperature:</b>	21.76 °C
<b>Relative Humidity:</b>	45%
<b>ATM Pressure:</b>	103.12 kPa

Testing was performed by Angel Escamilla on 2011-03-07 in 5 meter chamber 2.

## 7.7 Test Equipment List

Manufacturer	Description	Model	Serial Number	Calibration Date
Haefely	Immunity Simulator	Ecompact4	154978	2010-05-19
EM Test	Immunity Simulator	UCS 500 M/2	25087/1198-49	2010-09-01
Schaffner	CDN	CDN 8014	136	N/R
Velonex	Capacitive Clamp	V-3334	16495	N/R

**Statement of Traceability:** BACL Corp. attests that all calibrations or verifications have been performed according to NVLAP requirements, traceable to the NIST.

**7.8 Electrical Fast Transient Test Data (EN 61000-4-4)**

EN61000-4-4 Test Points		Test Levels (kV)							
		+0.25	-0.25	+0.5	-0.5	+1.0	-1.0	+2.0	-2.0
AC Power Line	L1+L2+Earth	-	-	A	A	A	A	-	-

EN61000-4-4 Test Points		Test Levels (kV)							
		+0.25	-0.25	+0.5	-0.5	+1.0	-1.0	+2.0	-2.0
Telecom Line		-	-	A	A	-	-	-	-

Note:        A ----- Performance Criteria A  
               B ----- Performance Criteria B  
               C ----- Performance Criteria C  
               - ----- Not Applicable

The EUT was subjected to Electrical Fast Transients Tests required by EN 55024:1998 + A1:2001 + A2:2003 and all lower levels specified in EN 61000-4-4.

Both EUT have the same results.



## 8 EN 55024 §4.2.5 – Surges EN 61000-4-5

### 8.1 Applicable Standard

As per EN 61000-4-5 §5: Test Levels

The preferential range of test levels is given in table 1.

**Table 1- Test levels**

Level	Open-circuit test voltage ±10 % (kV)
1	0.5
2	1.0
3	2.0
4	4.0
x	Special
NOTE x is an open class. This level can be specified in the product specification.	

The test levels shall be selected according to the installation conditions; classes of installation are given in B.3 of annex B.

All voltages of the lower test levels shall be satisfied (see 8.2).

For selection of the test levels for the different interfaces, see annex A.

### 8.2 Surges Test System

A Haefely Surge Immunity test system was used for all testing. Both positive and negative polarities of voltage up to 2 kV were applied to the AC input lines.

### 8.3 Surges Measurement Uncertainty

The measurement uncertainty with a 95 % confidence factor has determined that the applied surge is within 5% of the stated value.

### 8.4 Application of Surges

The EUT was setup in accordance with the setup described in EN 61000-4-5 and the test was performed according to the procedures described in the standard.

### 8.5 Test Setup Block Diagram

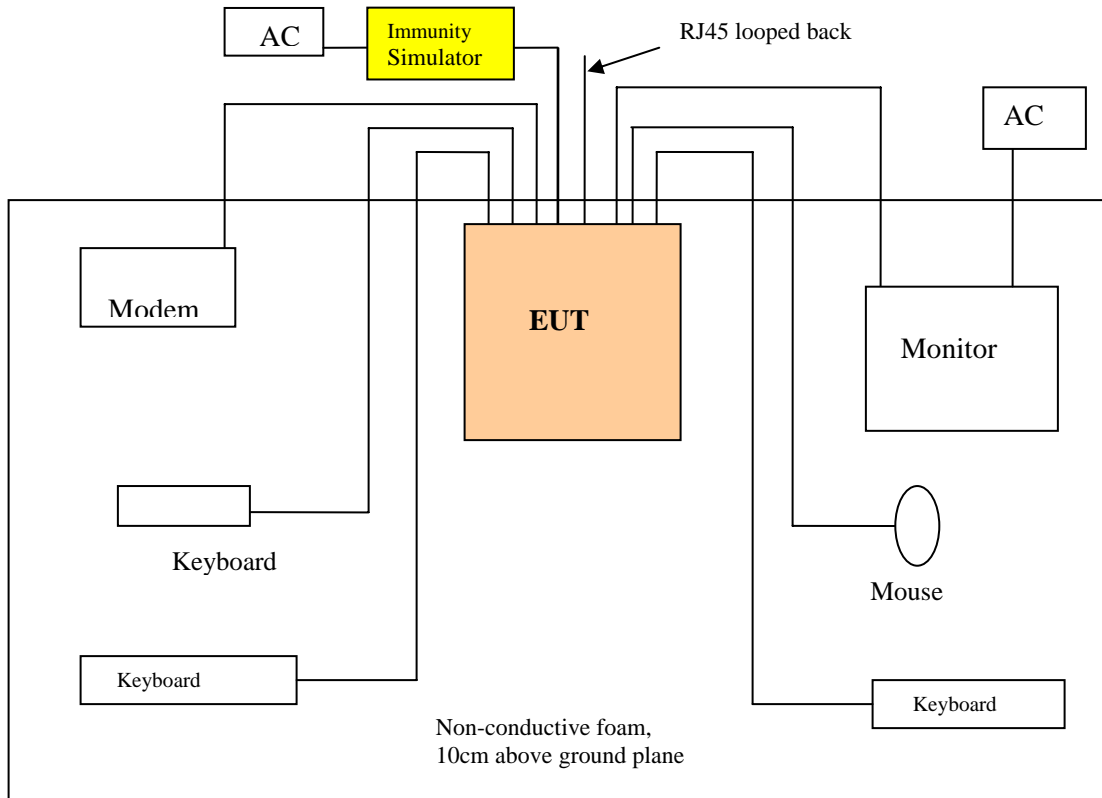

### 8.6 Environmental Conditions

#### 5017C-TF

<b>Temperature:</b>	22.54 °C
<b>Relative Humidity:</b>	55%
<b>ATM Pressure:</b>	105 kPa

Testing was performed by Angel Escamilla on 2011-03-04 in 5 meter chamber 2.

#### 1017C-TF

<b>Temperature:</b>	21.76 °C
<b>Relative Humidity:</b>	45%
<b>ATM Pressure:</b>	103.12 kPa

Testing was performed by Angel Escamilla on 2011-03-07 in 5 meter chamber 2.

## 8.7 Test Equipment List

Manufacturer	Description	Model	Serial Number	Calibration Date
EM Test	Immunity Simulator	UCS 500 M/2	25087/1198-49	2010-09-01
Haefely	Immunity Simulator	Ecompact4	154978	2010-05-19

*Statement of Traceability:* **BACL Corp.** attests that all calibrations or verifications have been performed according to NVLAP requirements, traceable to the NIST.

## 8.8 Surges Test Data (EN 61000-4-5)

**Table 1: AC Power Line**

Level	Voltage (kV)	Pole	Path	Pass	Fail
1	0.5	±	L-N, L-PE, N-PE	A	-
2	1	±	L-N, L-PE, N-PE	A	-
3	2	±	L-PE, N-PE	A	-
4	4	±	L-N, L-PE, N-PE	-	-

Note:           A ----- Performance Criteria A  
                   B ----- Performance Criteria B  
                   C ----- Performance Criteria C  
                   - ----- Not Applicable

The EUT was subjected to the Surge Immunity Test required by EN 55024: 1998 + A1: 2001 + A2: 2003 and all lower levels specified in EN 61000-4-5.

Both EUT have the same results.

## 9 EN 55024 §4.2.3.2 – Continuous Conducted Disturbance EN 61000-4-6

### 9.1 Applicable Standard

#### As per EN 61000-4-6 §5: Test Levels

No tests are required for induced disturbances caused by electromagnetic fields coming from intentional RF transmitters in the frequency range 9 kHz to 150 kHz.

**Table 1- Test levels**

Frequency range 150 kHz-80 MHz		
Level	Voltage level (e.m.f.)	
	$u_0$ dB(PV)	$u_0$ v
1	120	1
2	130	3
3	140	10
X <sup>1)</sup>	Special	
<sup>1)</sup> X is an open level.		

The open-circuit test levels (e.m.f.) of the unmodulated disturbing signal, expressed in r.m.s., are given in Table 1. The test levels are set at the EUT port of the coupling and decoupling devices, see 6.4.1. For testing of equipment, this signal is 80% amplitude modulated with a 1 kHz sine wave to simulate actual threats. The effective amplitude modulation is shown in Figure 4. Guidance for selecting test levels is given in Annex C.

### 9.2 Continuous Conducted Disturbance Test

An EM Test CWS500C Continuous Wave Simulator was used to perform the test. The EUT was subjected to 3 V rms, AM modulated (1 kHz sinewave at 80% depth), conducted signals from 0.15 MHz to 80 MHz. CDN coupling and de-coupling networks were utilized to inject the signal onto the power line using the 6.2.2 method. The clamp injection method of 6.2.3 was used to inject the signal onto the I/O lines.

### 9.3 Continuous Conducted Disturbance Measurement Uncertainty

The measurement uncertainty with a 95 % confidence factor has determined that the applied voltage level is within 0.25 V of stated value.

### 9.4 Application of Continuous Conducted Disturbance

The EUT was setup according to the EN 61000-4-6 and the test shall be performed with the test generator connected to each of the coupling and decoupling devices in turn while the other non-excited RF input ports of the coupling devices are terminated by a 50  $\Omega$  load resistor. The frequency range is 150 kHz to 80 MHz. When a CDN is not applicable the injection method should be used and a monitor probe is used to monitor the current injected.

### 9.5 Test Setup Block Diagram

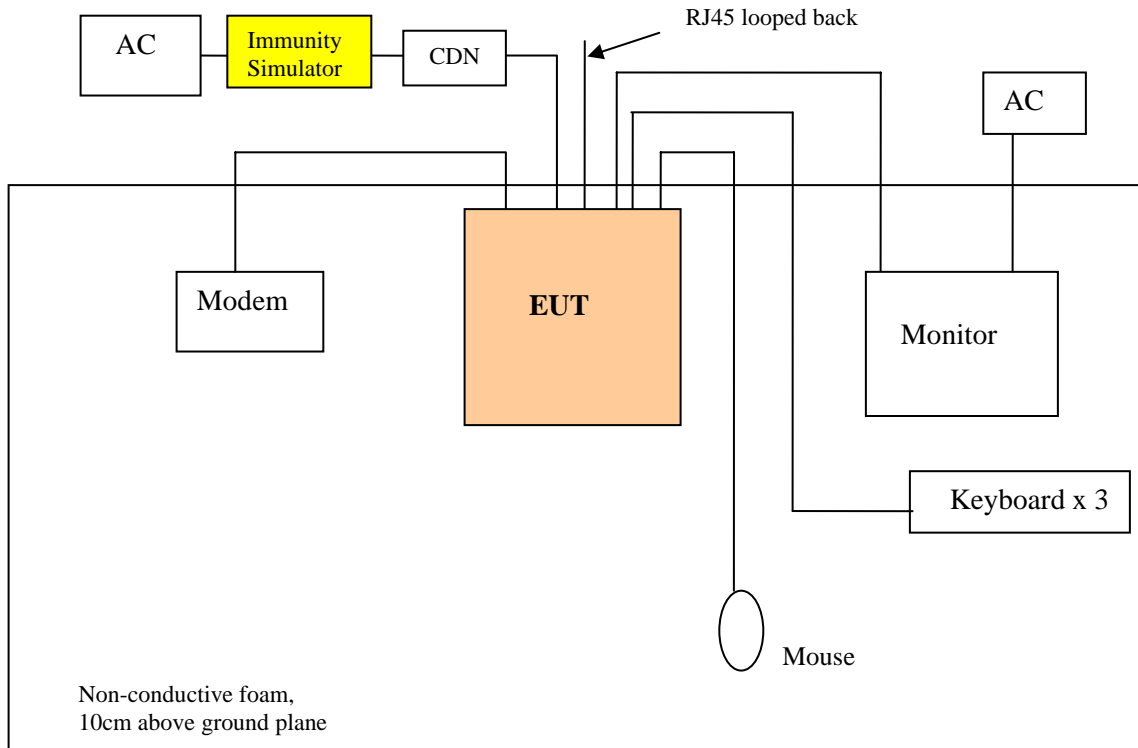

### 9.6 Environmental Conditions

#### 5017C-TF

<b>Temperature:</b>	22.54 °C
<b>Relative Humidity:</b>	55%
<b>ATM Pressure:</b>	105 kPa

Testing was performed by Angel Escamilla on 2011-03-04 in 5 meter chamber 2.

#### 1017C-TF

<b>Temperature:</b>	21.76 °C
<b>Relative Humidity:</b>	45%
<b>ATM Pressure:</b>	103.12 kPa

Testing was performed by Angel Escamilla on 2011-03-07 in 5 meter chamber 2.

## 9.7 Test Equipment List

Manufacturer	Description	Model	Serial Number	Calibration Date
EM Test	Immunity Generator	CWS500C	309338	2010-07-15
FCC	CDN	FCC-801-M3-25A	1001	2009-05-18 <sup>1</sup>
EM Test	CDN	CDN T8 RJ45	309341	2010-07-07

Note 1: Based on a 2 year calibration cycle

*Statement of Traceability:* **BACL Corp.** attests that all calibrations or verifications have been performed according to NVLAP requirements, traceable to the NIST.

## 9.8 Continuous Conducted Disturbance Test Data (EN 61000-4-6)

AC Power Line  
 Modulation: Amplitude, 80%, 1 kHz sine wave  
 Severity Level:  $\underline{3}$  Vrms

### AC Power Line

Level	Voltage Level (e.m.f.) $U_0$	Pass	Fail
2	3 Vrms	A	-

### Telecom Line

Level	Voltage Level (e.m.f.) $U_0$	Pass	Fail
2	3 Vrms	A	-

Note: A ----- Performance Criteria A  
 B ----- Performance Criteria B  
 C ----- Performance Criteria C  
 - ----- Not Applicable

The EUT was subjected to a 3-volt/meter, 80% Amplitude modulated, 1 kHz sine wave field as required by EN 55024:1998 + A1:2001 + A2:2003 and the level specified by EN 61000-4-6.

Both EUT have the same results.

## 10 EN 55024 §4.2.6 – Voltage Dips and Interruptions EN 61000-4-11

### 10.1 Applicable Standard

As per EN 61000-4-11 §5: Test Levels

**Immunity, Input a.c. power ports (including equipment marketed with a separate a.c./d.c. power converter)**

	Environmental phenomenon	Test specification	Units	Basic Standard	Remarks	Performance criterion
4.2	Voltage dips	>95	% reduction period	IEC 61000-4-11	See <sup>2)</sup>	B
		0.5				C
4.3	Voltage interruptions	30	% reduction periods	IEC 61000-4-11	See <sup>2)</sup>	C
		300				

### 10.2 Voltage Dips and Interruptions Test System

An EM Test Immunity Simulator system is used for all testing.

### 10.3 Voltage Dips and Interruptions Measurement Uncertainty

The measurement uncertainty with a 95 % confidence factor has determined that the applied voltage level is within 0.25 V of the stated value.

### 10.4 Application of Voltage Dips and Interruptions

The EUT was setup in accordance with the setup described in EN61000-4-11 and the test was performed according to procedures described in the standard.

### 10.5 Test Setup Block Diagram

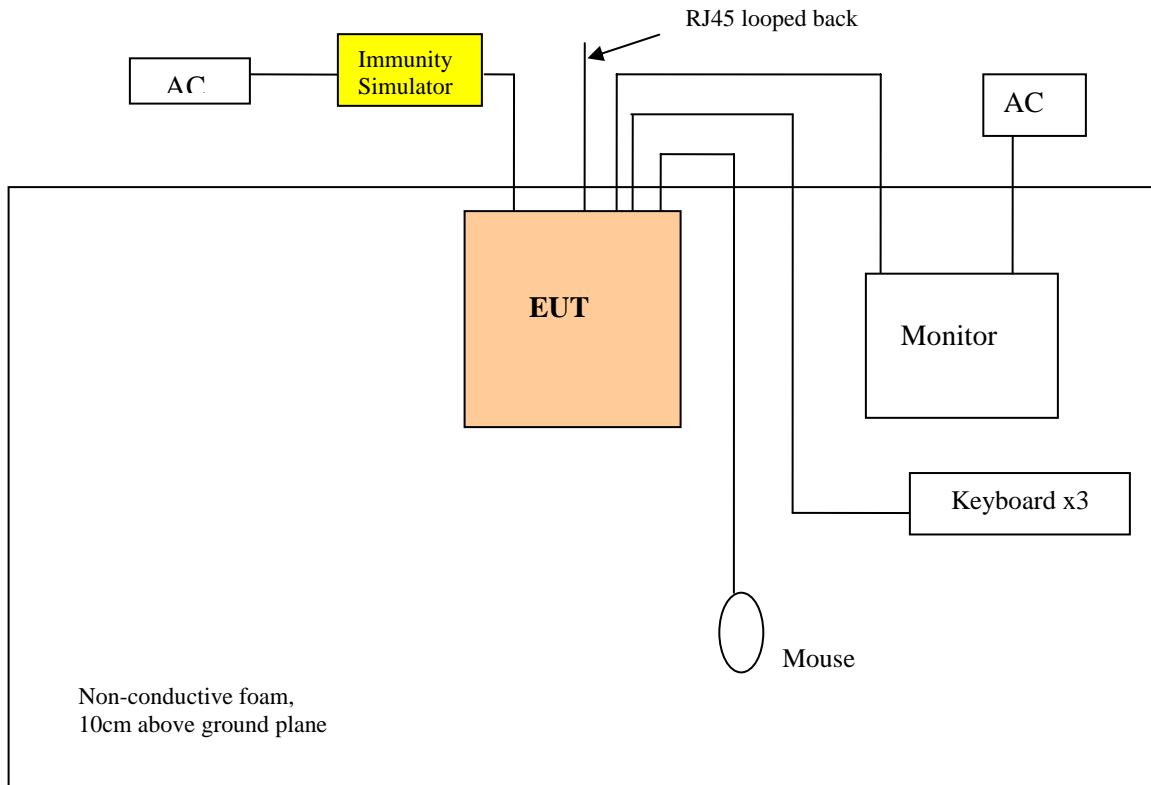

### 10.6 Environmental Conditions

#### 5017C-TF

<b>Temperature:</b>	22.54 °C
<b>Relative Humidity:</b>	55%
<b>ATM Pressure:</b>	105 kPa

Testing was performed by Angel Escamilla on 2011-03-04 in 5 meter chamber 2.

#### 1017C-TF

<b>Temperature:</b>	21.76 °C
<b>Relative Humidity:</b>	45%
<b>ATM Pressure:</b>	103.12 kPa

Testing was performed by Angel Escamilla on 2011-03-07 in 5 meter chamber 2.



## 10.7 Test Equipment List

Manufacturer	Description	Model	Serial Number	Calibration Date
Haefely	Immunity Simulator	Ecompact4	154978	2010-05-19
EM Test	Immunity Simulator	UCS 500 M/2	25087/1198-49	2010-09-01
EM Test	Immunity Generator	MV 2616	25086	N/R

*Statement of Traceability:* **BACL Corp.** attests that all calibrations or verifications have been performed according to NVLAP requirements, traceable to the NIST.

## 10.8 Voltage Dips and Interruptions Test Data (EN 61000-4-11)

### AC Power Line

Phenomenon	%	Cycles	Phase Angle	Pass	Fail
Voltage Dip	95%	0.5	0/180	A	-
Voltage Dip	30%	30	0/180	C	-
Short Interruption	95%	300	0/180	C	-

Note:           A ----- Performance Criteria A  
                   B ----- Performance Criteria B  
                   C ----- Performance Criteria C  
                   - ----- Not Applicable

The EUT was subjected to the Voltage Dips and Interruptions Immunity Tests required by EN 55024:1998 + A1:2001 + A2:2003 and all lower levels specified in EN 61000-4-11.

Both EUT had the same results.

## 11 EXHIBIT A - CE PRODUCT LABELING REQUIREMENTS

### 11.1 Label Information

1. The CE conformity marking must consist of the initials 'CE' taking the following form:



*If the CE marking is reduced or enlarged, the proportions given in the above graduated drawing must be respected.*

2. The CE marking must have a height of at least 5 mm except where this is not possible on account of the nature of the apparatus.
3. The CE marking must be affixed to the product or to its data plate. Additionally it must be affixed to the packaging, if any, and to the accompanying documents.
4. The CE marking must be affixed visibly, legibly, and indelibly.
5. The equipment class identifier must take a form to be decided by the Commission in accordance with the procedure laid down in Article 14.

Where appropriate it must include an element intended to provide information to the user that the apparatus makes use of radio frequency bands where their use is not harmonized throughout the Community.

It must have the same height as the initials 'CE'



Specifications: Text is black or white in color and is left justified. Labels are printed in indelible ink on permanent adhesive backing or silk-screened and shall be affixed at a conspicuous location on the EUT. The label can not be positioned on a removable portion of the EUT (e.g. battery cover).

**11.2 Suggested Label Location on EUT**



*5017C-MF*

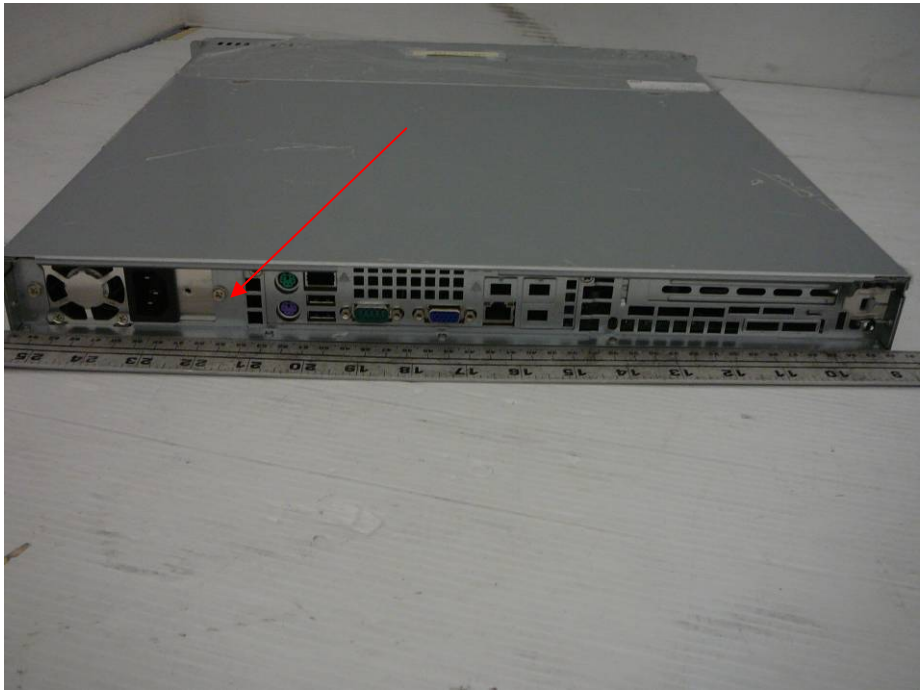

*5017C-MTF*

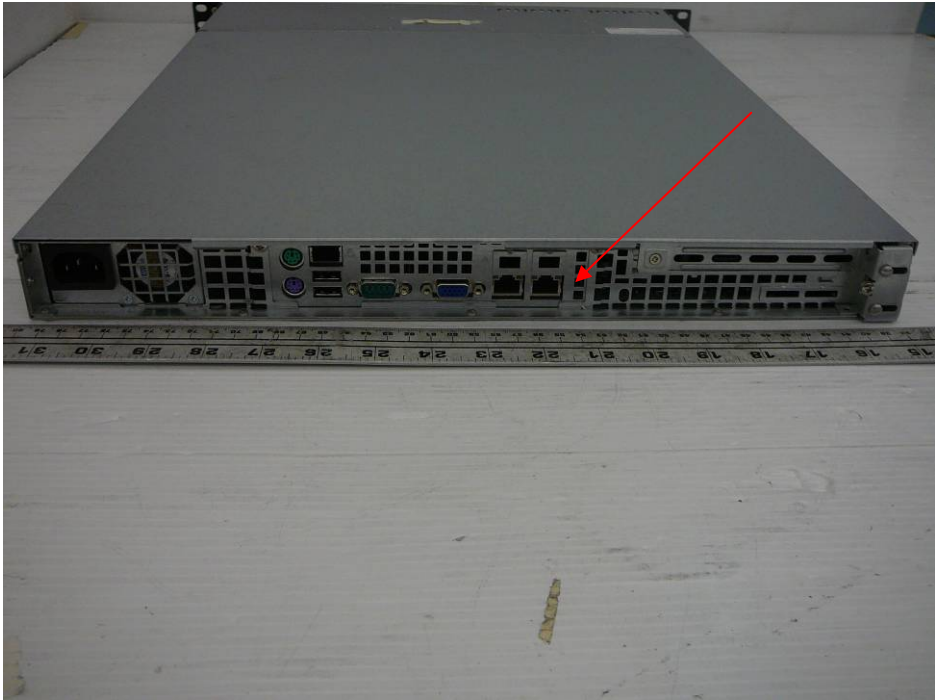

*1017C-TF*

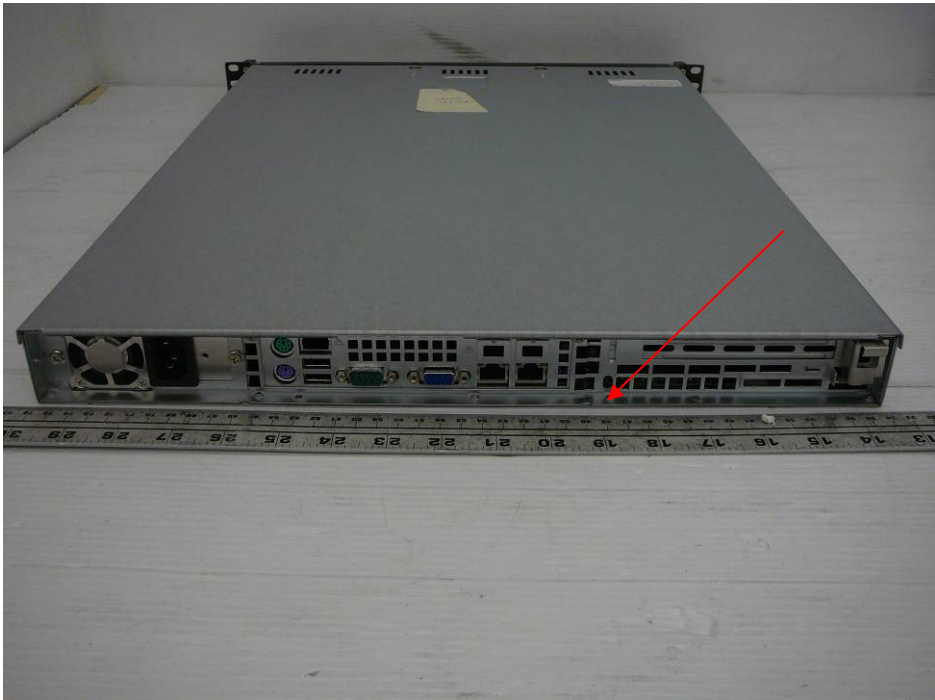

*5017C-TF*

## 12 Exhibit B – Test Setup Photographs

### 12.1 Electrostatic Discharge (EN 61000-4-2)-5017C-TF



### 12.2 ESD Contact Points View 1 – (Direct Contact – Blue Line, Air Contact – Red Line)-5017C-TF, 5017C-MF, 5017C-MTF

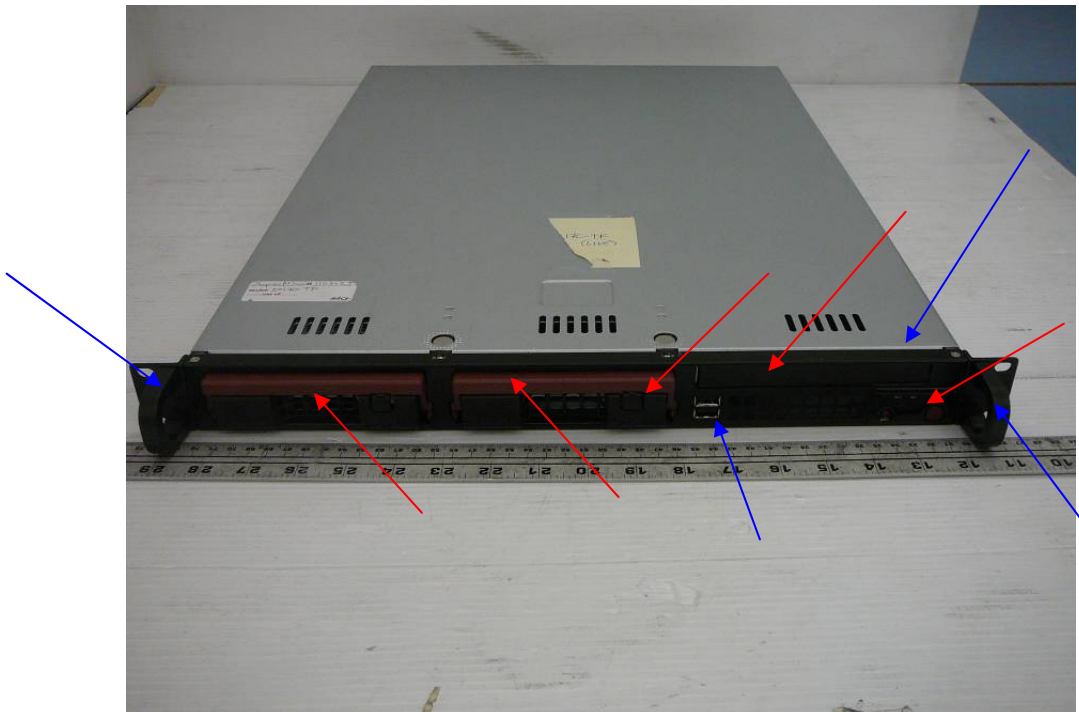

**12.3 ESD Contact Points View 2 – (Direct Contact – Blue Line. Air Contact – Red Line) -5017C-TF**



**12.4 Electrostatic Discharge (EN 61000-4-2)-1017C-TF**



**12.5 ESD Contact Points View 1 – (Direct Contact – Blue Line, Air Contact – Red Line)-1017C-TF**



**12.6 ESD Contact Points View 2 – (Direct Contact – Blue Line. Air Contact – Red Line) -1017C-TF**

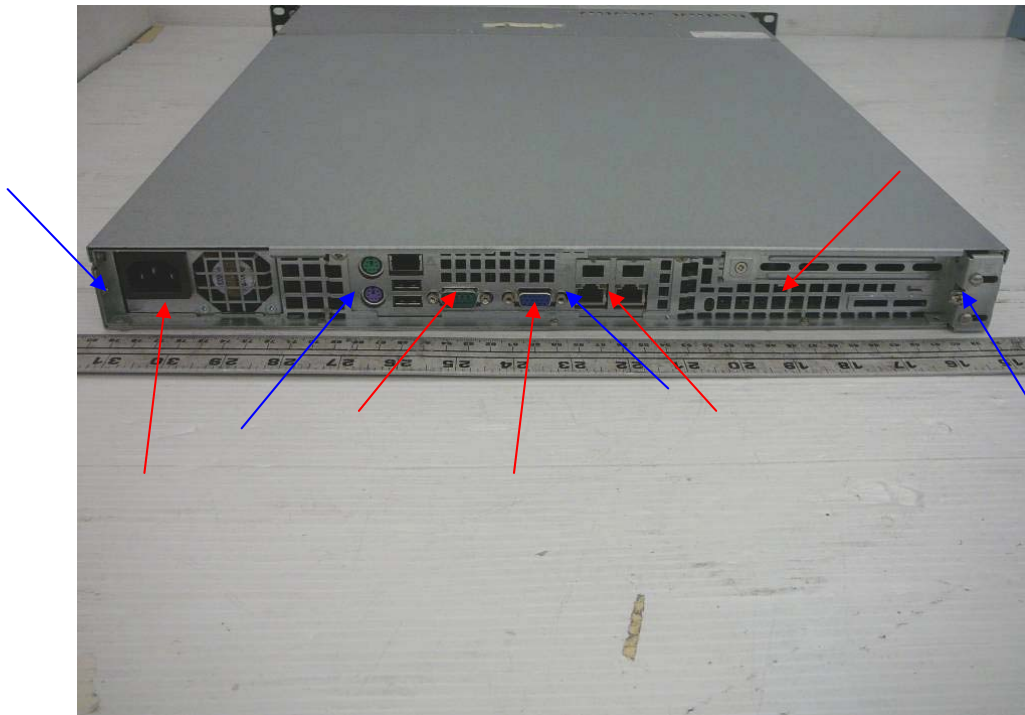

**12.7 Continuous Radiated Immunity (EN 61000-4-3)-Front View-5017C-TF**



**12.8 Continuous Radiated Immunity (EN 61000-4-3)-Front View-1017C-TF**





**12.9 Electrical Fast Transients (EN 61000-4-4) – AC Line-5017C-TF**



**12.10 Electrical Fast Transients (EN 61000-4-4) – AC Line-1017C-TF**

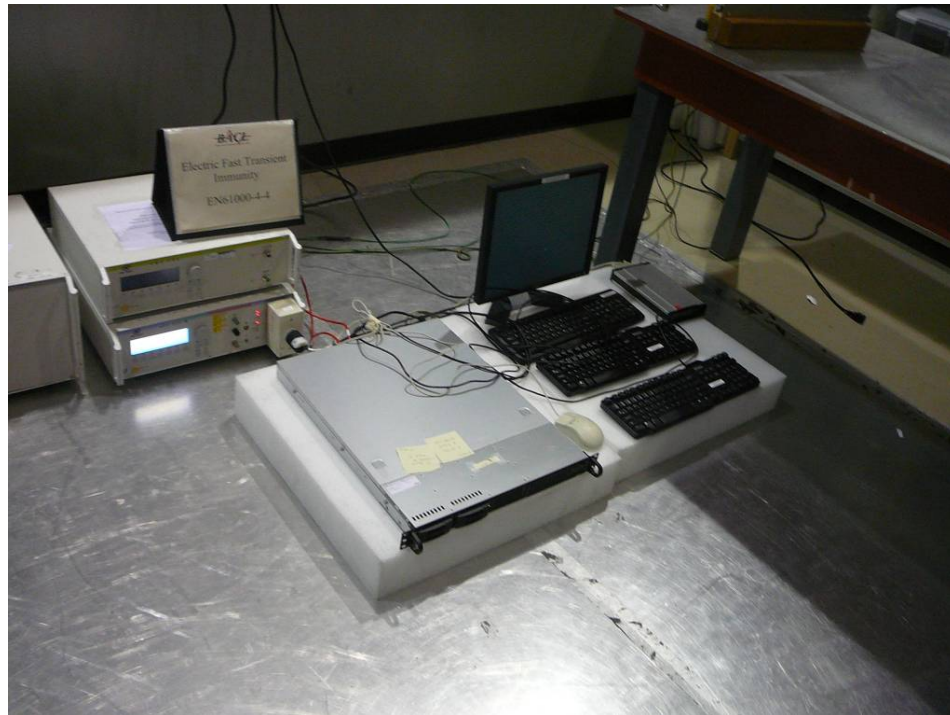

**12.11 Electrical Fast Transients (EN 61000-4-4) – Signal Line-5017C-TF**



**12.12 Electrical Fast Transients (EN 61000-4-4) – Signal Line-1017C-TF**



### 12.13 Surges (EN 61000-4-5)-AC Line-5017C-TF



### 12.14 Surges (EN 61000-4-5)-AC Line-1017C-TF

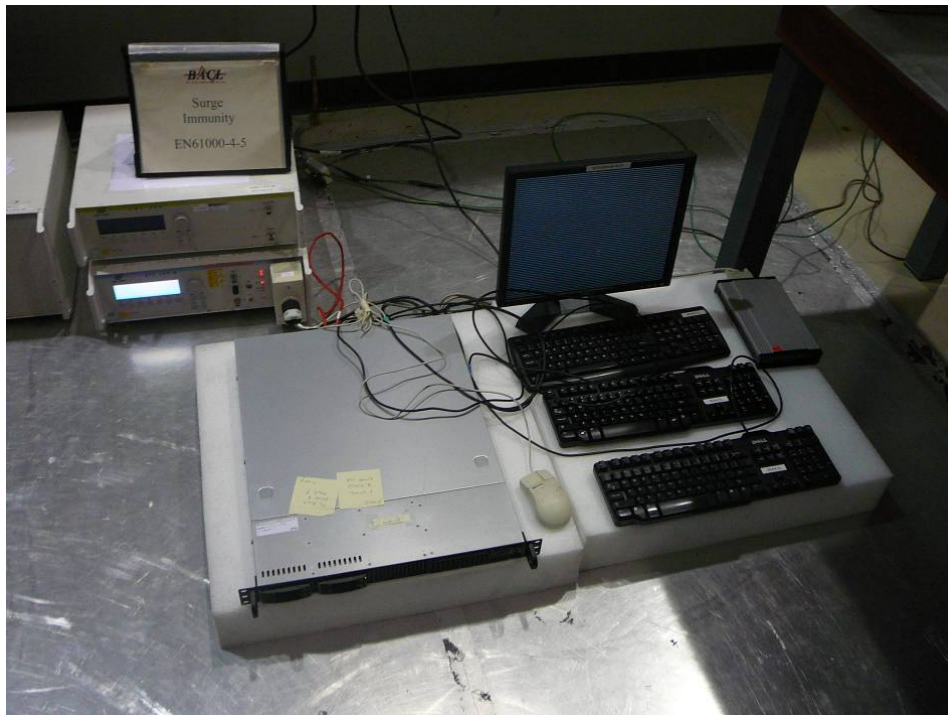

**12.15 Continuous Conducted Immunity (EN 61000-4-6) – Power Line-5017C-TF**



**12.16 Continuous Conducted Immunity (EN 61000-4-6) – Power Line-1017C-TF**

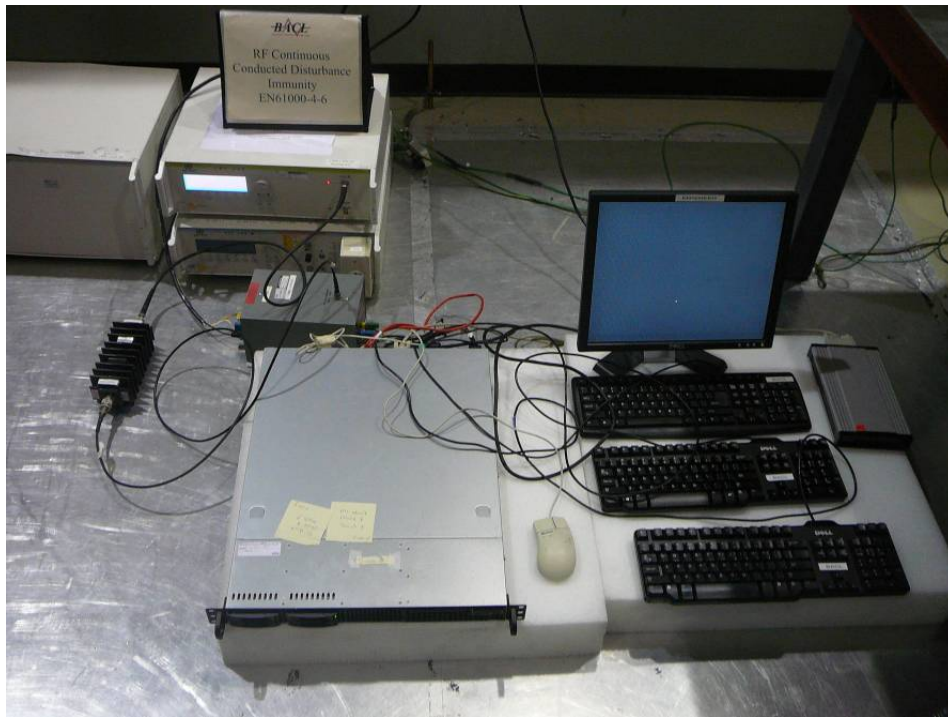

**12.17 Continuous Conducted Immunity (EN 61000-4-6) – Signal Line-5017C-TF**



**12.18 Continuous Conducted Immunity (EN 61000-4-6) – Signal Line-1017C-TF**



### 12.19 Voltage Dips and Interruptions (EN 61000-4-11)-5017C-TF



### 12.20 Voltage Dips and Interruptions (EN 61000-4-11)-1017C-TF

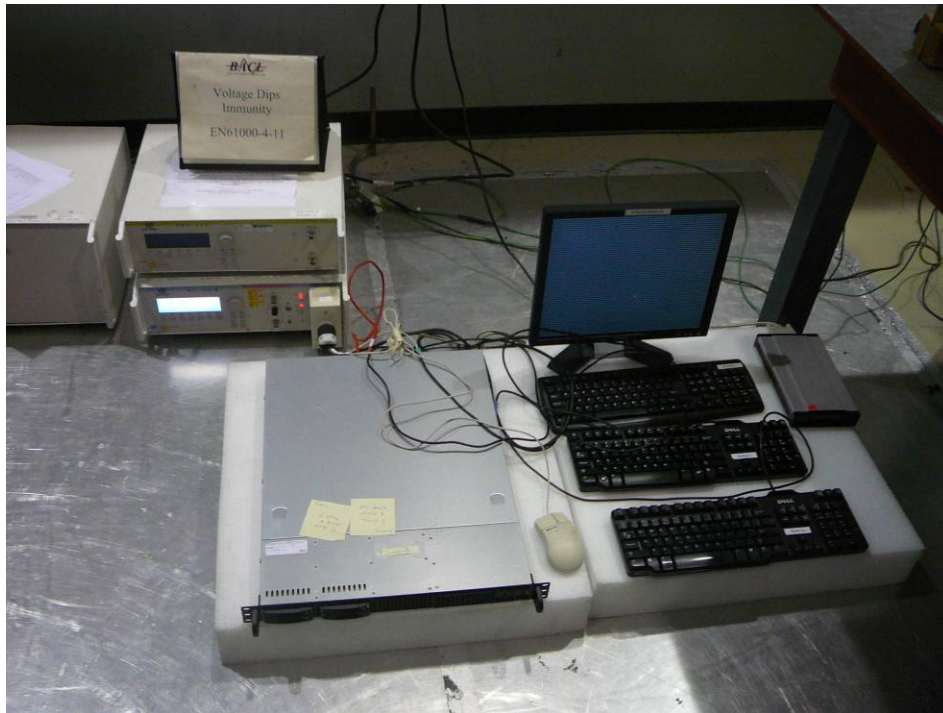

### 13 Exhibit C – EUT Photographs

#### 13.1 EUT Front View-5017C-TF



#### 13.2 EUT Rear View-5017C-TF



**13.3 EUT Chassis Open View-5017C-TF**



**13.4 EUT Front View -1017C-TF**





**13.5 EUT Rear View -1017C-TF**



**13.6 EUT Cover off View -1017C-TF**

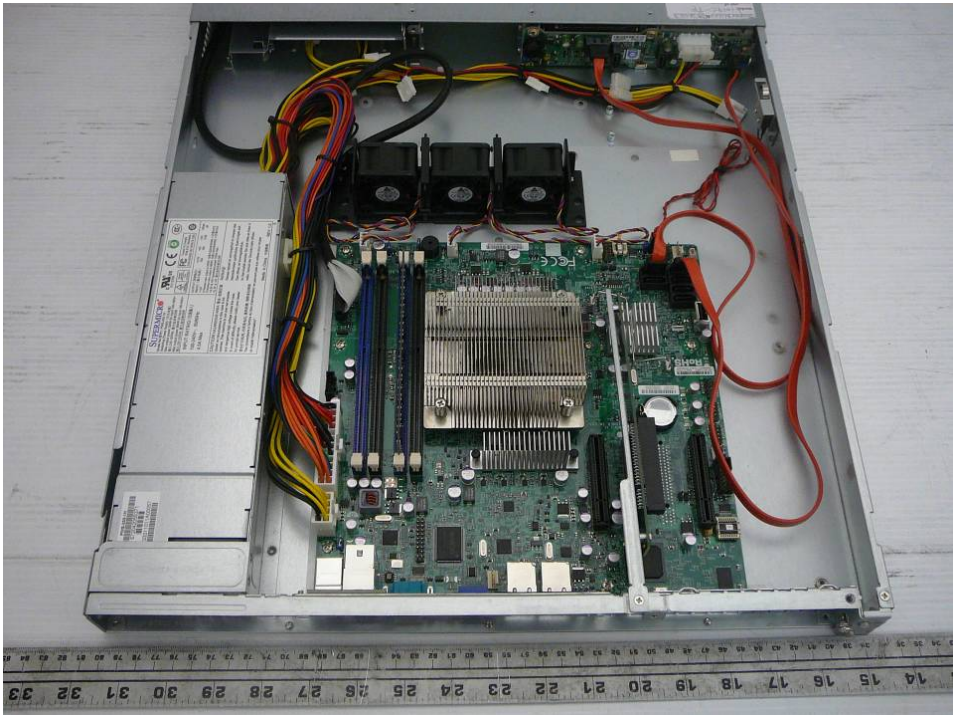

13.7 EUT Power Top View-5017C-TF



13.8 EUT Power Top View-1017C-TF



## 14 Appendix I - Declaration of Similarity



**HEADQUARTERS**  
 980 Rock Avenue, San Jose, CA 95131 USA  
 Tel: 408-503-8000 Fax: 408-503-8008  
 www.supermicro.com

### Statement of Similarity

**Company Name:** Super Micro Computer, Inc. (hereinafter "Super Micro")  
**Contact Name:** Victor Yuan  
**Date:** 2011/04/04

**Subject:** Product similarity declaration

**To:** Whom it may concern,

Super Micro hereby declares that the product tested as 5017C-TF is electronically similar to its serial models and depopulated versions listed below.

5017C-LF	X9SCL-F
5017C-MTRF	X9SCL-F
5017C-MF	X9SCL-F
5017C-MTF	X9SCL-F
5017C-TF	X9SCM-F

On behalf of Super Micro,

**Compliance Engineer:**   
 Victor Yuan

**Date:** 2011/04/04

---END OF REPORT---